

Single-Pair Ethernet and Ethernet-APL Universal Switch User Manual



Overview:

Single-Pair Ethernet (SPE) is a single-pair Ethernet technology based on the IEEE 802.3cg-2019 standard. It represents a new trend in industrial automation data transmission applications and serves as the foundation for the development of the Industrial Internet of Things (IIoT). SPE technology overcomes the limitations of high space requirements and high transmission costs associated with Ethernet, enabling Ethernet to meet communication needs from remote networks to field devices for the first time with reduced space requirements and lower costs. SPE transmits Ethernet data using only a single pair of twisted-pair copper wires (single pair) and simultaneously utilizes Power over Data Line (PoDL) technology—where twisted-pair cables transmit both data and power—to supply power to end devices such as various sensors, actuators, and cameras. SPE opens up more, even limitless, possibilities for industrial Ethernet and IoT data transmission.

Although the SPE physical layer uses a single pair of twisted-pair copper wires for transmission, the protocol layer retains the various upper-layer protocols of the original IEEE 802.3 standard, particularly the 10BASE-T1 standard, which is specifically tailored for industrial automation and building automation (which has two variants: short-cable multipoint 10BASE-T1S and long-cable point-to-point 10BASE-T1L), and provides better support for all types of upper-layer Industrial Ethernet protocols, such as PROFINET, MODBUS TCP/IP, Ethernet/IP, CC-Link IE, POWERLINK, and others.

Ethernet-APL (Ethernet Advanced Physical Layer) is a physical layer based on the 10BASE-T1L standard defined in IEEE 802.3cg-2019, developed specifically for process automation. It functions similarly to Single-Pair Ethernet (SPE), but establishes its own industry standards in certain areas, particularly regarding power over Ethernet (PoE), such as:

IEC TS 63444-2023 Industrial Networks—Ethernet-APL Port Profile Specification; IEEE Std 802.3-2022 IEEE Standard for Ethernet

Single-Pair Ethernet and Ethernet-APL Universal Switches

The FO2G-IE3G-10T1L10 universal switch for Single-Pair Ethernet (SPE) and Ethernet-APL integrates SPE and Ethernet-APL applications, enabling bidirectional, transparent data transmission between Single-Pair Ethernet connections and standard Ethernet connections. This product features 10 10BASE-T1L Single-Pair Ethernet ports, 3 Gigabit standard Ethernet ports, and 2 Gigabit SFP fiber ports; both Ethernet and fiber ports support redundant ring networks. It supports Power over Data Line (PoDL) at various voltage level ultra-wide power supply voltage range of 9–60 VDC to accommodate the various PoDL voltage and power levels specified by SPE and Ethernet-APL (hereinafter referred to as APL).

FO2G-IE3G-10T1L10 as a single-pair Ethernet switch:

With a power supply voltage of 24 VDC, it supports PoDL power classes 10, 11, and 12, with a PoDL output power of ≥ 12.63 W. With a power supply voltage of 54 VDC, it supports PoDL power classes 13, 14, and 15, with a PoDL output power of ≥ 79 W.

When used with Ethernet-APL, the Four Star Electronics FO2G-IE3G-10T1L10 functions as a field-integrated switch with a built-in power supply.

As an Ethernet-APL field switch, the FO2G-IE3G-10T1L10:

The power supply voltage is 12 VDC; it supports PoDL power levels A and C, with a PoDL output power of ≥ 1.1 W.

FO2G-IE3G-10T1L10 as an Ethernet-APL power switch:

The power supply voltage is 48 VDC, supporting PoDL power levels 3 and 4, with a maximum PoDL output power of 92 W.

The FO2G-IE3G-10T1L10 switch operates within an ultra-wide input voltage range of 9–60 VDC and selects its power supply voltage based on the specific SPE (APL) power-consuming devices (PDs) connected downstream. **The PoDL supply voltage output from each SPE port (APL port) equals the operating supply voltage input to this product.** The total PoDL power output from the 10 SPE ports (APL ports) equals the operating supply power input to this product (typically, a margin of 40% or more is recommended)

This product's PoDL power supply does not include PD detection or power classification (SCCP) processes. Instead, DIP switches are used to enable or disable PoDL power delivery on each SPE port (APL port). Power delivery to the powered device (PD) via the SPE cable begins immediately upon power-up, therefore, users must verify that the powered device (PD) supports PoDL power delivery and that the PD's PoDL voltage matches the operating voltage of the power supply connected to this product. If PoDL power delivery is not enabled, these considerations are not necessary.

Applications

■ Industrial Automation ■ Building Automation ■ Security Systems ■ Transportation Control Systems ■ Industrial Internet of Things

Single-Pair Ethernet and Ethernet-APL Universal Switches

Key Technical Specifications:

Parameter Category	Item	Refers to Specification
Standard Ethernet Port Parameters	Interface Type	3 standard Gigabit RJ45 connectors, 1000/100/10 Mbit/s auto-negotiation.
	Auto-negotiation	The Ethernet ports feature MDI/MDI-X auto-crossover functionality, supporting both straight-through and crossover cables.
	Maximum Transmission Distance	100 meters using Category 6 (Gigabit) or Category 5 (100 Mbit/s) 8-pair twisted-pair cable (Cat.6 or Cat.5).
	Network Port Protocols	IEEE 802.3, 1000Base-X, 100Base-TX, and 10BASE-T Ethernet standards.
	Ring Network Support	Supports Ethernet loop redundancy topologies.
Fiber Port Parameters	Number of Fiber Ports	Dual optical ports, single-fiber bidirectional transmission.
	Fiber Types	Single-mode 9/125, 10/125, 8.3/125 μm . Replaceable SFP modules support other fiber types.
	Fiber Interface	SFP pluggable optical modules, standard LC fiber connectors, transmission rate 1000 Mbps. Optical Port A: 1310 nm transmit / 1550 nm receive; Optical Port B: 1550 nm transmit / 1310 nm receive.
	Maximum Fiber Transmission Distance	20 km over single-mode fiber; for longer distances, replace the SFP optical module.
	Ring Network Support	Supports fiber ring network redundancy topology.
Single-pair Ethernet Port Parameters	Interface Type	5.08-3-pin pluggable spring-loaded terminal blocks.
	Data Rate	10 Mbit/s full-duplex, compliant with the 10BASE-T1L standard, IEEE 802.3cg-2019.
	Output Signal Peak-to-Peak	The factory default peak-to-peak signal voltage (V_{pp}) is 1.0 V. To set V_{pp} to 2.4 V, remove the shorting caps (jumper caps) on pin J3 of the 10 communication sub-boards on the circuit board.
	Transmission Medium	SPE single-pair twisted-pair cable, 26 AWG (0.14 mm^2) to 14 AWG (2 mm^2).
	Maximum transmission distance	1,000 meters. If using PoDL for power supply, the distance is limited by the power output, the connected terminal instruments, and the cable cross-sectional area. The national standard for use as an Ethernet-APL field switch is a maximum of 200 meters; when used as a power switch, the national standard is a maximum of 1,000 meters.
	Connection Indicators	SPE port communication status indicator and PoDL indicator.
	PoDL Power Levels	When the supply voltage is 24 VDC, SPE power classes 10, 11, and 12 are supported. When the supply voltage is 54 VDC, SPE power classes 13, 14, and 15 are supported. When the supply voltage is 12 VDC, Ethernet-APL power classes A and C are supported. When the power supply voltage is 48 VDC, it supports Ethernet-APL power levels 3 and 4.
	SPE Interface Protection	Features TVS surge protection and ESD protection, compliant with standards IEC 61000-4-4, IEC 61000-4-5, and IEC 61000-4-2.
	Number of Ports	10 SPE ports (APL ports).
SPE Communication Protocol	IEEE 802.3cg-2019, 10Base-T1L, transparent transmission, supports all the upper layer protocols such as PROFINET, MODBUS TCP/IP, Ethernet/IP, CC-Link IE, POWERLINK, etc.	
General Specifications	Operating Supply Voltage	Any voltage between 9 and 60 VDC, with reverse polarity protection and surge protection; the different SPE (APL) downstream power-consuming devices.
	Operating Power Consumption	When not using PoDL power, the power consumption shall not exceed 5 W; when using PoDL power, the power consumption shall be the sum of the power of all power-consuming devices, plus a margin of at least 40%.
	Interface Isolation	Ethernet ports are isolated from one another; Ethernet ports are isolated from SPE ports; and Ethernet ports are isolated from power ports, with an isolation voltage of 1500 VDC. There is no electrical isolation between individual SPE (APL) ports, between SPE (APL) ports and the input power port (shared PoDL voltage).
	Protection Rating	IP20

Single-Pair Ethernet and Ethernet-APL Universal Switches

	Operating Temperature	-20°C to +75°C.
	Dimensions	96 mm × 116 mm × 140 mm (L × W × H), weight 1.2 kg.
	Mounting Method	Mounting on a standard 35mm DIN rail.

Product Appearance and Component Descriptions:

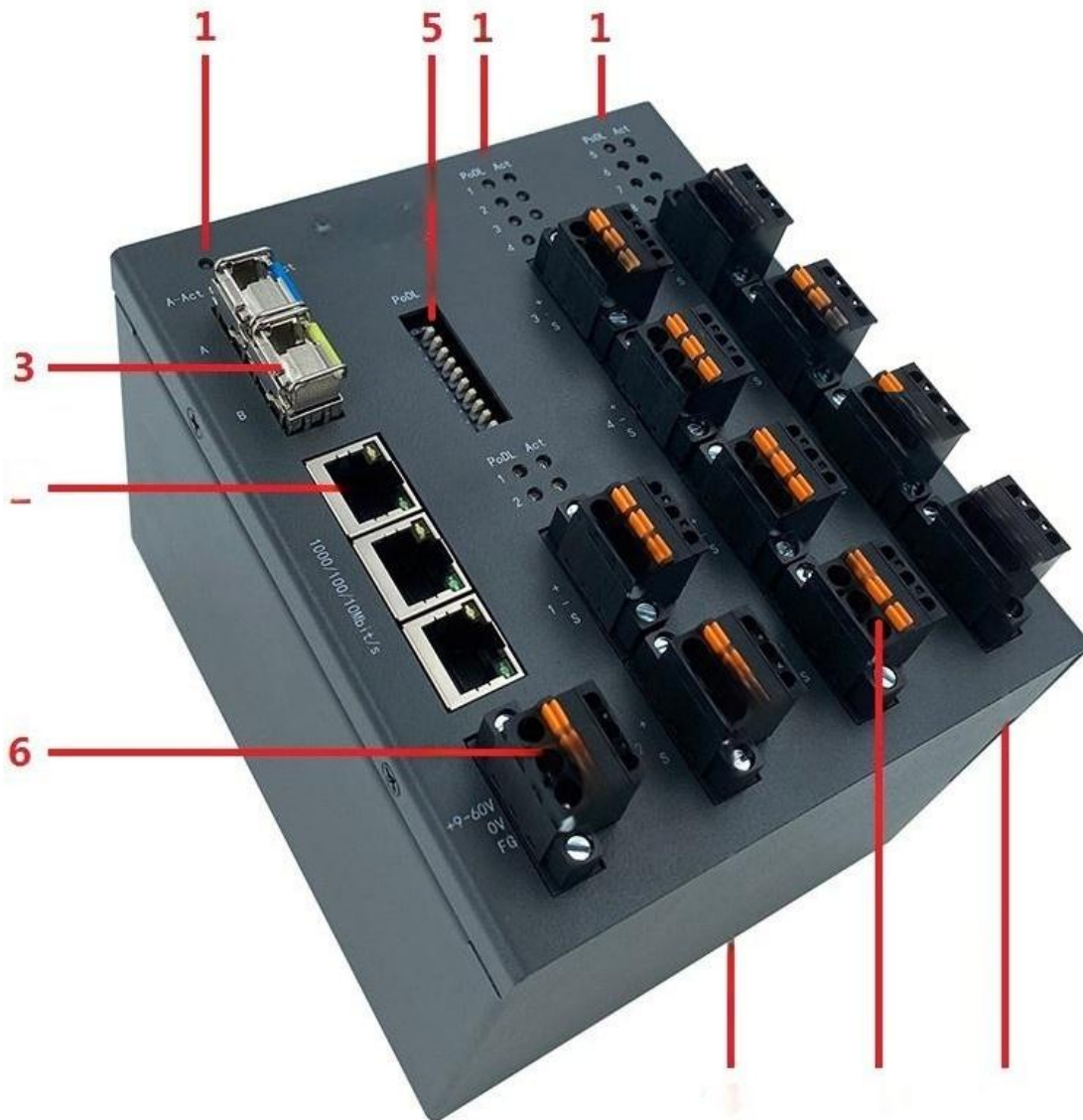

Single-Pair Ethernet and Ethernet-APL Universal Switches

1. Indicator Lights: Names and functions of the LED indicator lights on the panel.

Indicator Name	Indicator Status		
	On	On	Off
PWR	Power supply is operating normally	Fault	Power not connected or hardware failure
Green LED on the network port	Connection is normal	Data is being transmitted through the network port	The Ethernet port is not connected or the connection is incorrect
Yellow light on the Ethernet port	Not in use		
A-Act	A Optical Port Connection is Normal	A optical port is transmitting data	A: Fiber disconnected from the optical port or power off at the remote device
B-Act	B optical port connection is normal	B optical port is transmitting data	The fiber on optical port B is disconnected or the remote device is powered off
Act1-10	SPE connection is normal	SPE port is transmitting data	The SPE port is not connected or is connected incorrectly
PoDL 1-10	Enable PoDL power supply	PoDL power supply is abnormal	PoDL power is turned off or the SPE cable is shorted

2 or 3 standard 1000/100/10 Mbit/s RJ45 Ethernet ports, supporting a ring network redundancy topology. Signal definitions are as follows:

RJ45 Ethernet Port Signal Definitions:

Pin	Signal Name	Function	Type
1	Rx+	Receive Data (Positive)	Input
2	Rx-	Receive Data Negative	Input
3	Tx+	Transmit data (positive)	Output
4	BI_D3+	Bidirectional data positive	Bidirectional
5	BI_D3-	Bidirectional Data Negative	Bidirectional
6	Tx-	Transmit Data Negative	Output
7	BI_D4+	Bidirectional data (positive)	Bidirectional
8	BI_D4-	Bidirectional Data Negative	Bidirectional

3. Fiber Ports A and B: The switch features two 1000 Mbit/s fiber ports, A and B, which use pluggable and replaceable SFP modules. Data is transmitted bidirectionally over a single fiber. Connections to other fiber switches follow the A→B, B→A principle, and the switch supports a fiber ring network redundancy topology.

The standard SFP fiber modules for this product are 1000 Mbit/s single-mode, single-fiber modules with LC connectors, supporting a maximum transmission distance of 20 kilometers. Users can replace these with other SFP fiber modules, such as 100 Mbit/s, multimode, single-mode, SC connectors, or modules with longer transmission distances.

Single-Pair Ethernet and Ethernet-APL Universal Switches

4. 10 single-pair Ethernet SPE connectors (APL connectors) 1–10, using 5.08-3-pin pluggable spring-loaded terminals; the signal definitions are as follows:

Terminal Name	SPE (APL)10BASE-T1L	Type
+	D+, SPE Positive Signal (Rx/Tx+)	Input/Output
-	D-, SPE negative signal (Rx/Tx-)	Input/Output
S	Shield terminal; connect to the SPE cable shield.	-

5. PoDL DIP Switch: This DIP switch enables or disables PoDL power supply. This 10-position DIP switch controls the activation and deactivation of power delivery via the data lines for the corresponding 10 SPE ports (APL ports). When a DIP switch is set downward in the direction of the arrow, it is ON; the corresponding SPE port (APL port) enables PoDL power delivery, and the corresponding PoDL indicator light illuminates. At this point, the SPE cable transmits both data and power, and the output voltage is the operating power supply voltage for this product. Toggling the switch upward sets it to OFF; the corresponding SPE port (APL port) disables PoDL power supply, and the corresponding PoDL indicator turns off. At this point, the corresponding SPE port transmits data only and does not supply power.

This product's PoDL power supply does not include a PD detection or power classification (SCCP) process. When the toggle switch is set to ON, power is supplied to the powered device (PD) via the SPE cable immediately after power-up. Therefore, users must confirm that the powered device supports PoDL power supply **and that its PoDL supply voltage matches the operating voltage of this product**. If PoDL power supply is not enabled, these considerations are not necessary.

6. Power Terminals: This product supports any operating voltage between 9 and 60 V. When PoDL power supply is enabled, ensure that the operating voltage connected to this product matches the power supply voltage of the end-user power-consuming device (referred to as a PD device).

Terminal Name	Description
+9–60 V	Connect to the positive terminal of any DC power source between 9 and 60 V
0V	Connect to the negative terminal of any DC power source between 9 and 60V
FG	Shield Ground (Chassis Ground)

Connect the power supply to this switch according to the following principles:

- As a single-pair Ethernet switch:
The power supply voltage is 20V–30VDC (nominal 24 V DC), supporting PoDL power classes 10, 11, and 12 over a single Ethernet pair, with a PoDL output power of $\geq 12.63\text{W}$ per SPE port.

Single-Pair Ethernet and Ethernet-APL Universal Switches

The power supply voltage is 50 V to 58 V DC (nominal value 54 V DC), supporting Single-Pair Ethernet PoDL power classes 13, 14, and 15, with a PoDL output power of ≥ 79 W per SPE port.

➤ As an Ethernet-APL field switch:
The power supply voltage is 9 V to 15 V DC (nominal 12 V DC); in this configuration, the APL ports function as spurs and support PoDL power levels A and C, with a PoDL output power of ≥ 1.1 W per APL port.

➤ As an Ethernet-APL power switch:
The power supply voltage is 45 V to 50 V DC (nominal 48 V DC). In this mode, the APL port functions as a trunk and supports PoDL power levels 3 and 4, with a maximum PoDL output power of 92 W per APL port.

Special Note: When PoDL power supply is enabled, if the power supply voltage connected to this product is 54V, do not use an SPE (APL) cable to connect terminal receiving devices with voltages of 24V or lower, otherwise the terminal receiving devices may be damaged.

When PoDL power supply is enabled, the power required by this product should exceed the sum of the power consumption of all SPE (APL) terminal devices plus a margin of at least 40%; if PoDL power supply is not used, the power consumption of this product does not exceed 5 watts. The maximum PoDL output power for each SPE port on this product is 92W.

Of course, if PoDL power supply is not enabled, this product has no specific requirements for the operating power supply voltage; it can operate within a range of 9–60 DC

Setup instructions for the internal circuit board (usually no setup required)

When the FO2G-IE3G-10T1L10 is used as an APL field switch, the SPE output signal peak-to-peak voltage (V_{pp}) must be 1.0 V (factory default setting) Pin J3 on the 10 communication interface subboards mounted on the main board is shorted with a jumper cap at the factory.

When the FO2G-IE3G-10T1L10 is used as a power switch, the SPE output signal peak-to-peak voltage (V_{pp}) must be 2.4 V. in which case it may be necessary to remove the shorting caps (jumper caps) from pin J3 on the 10 communication interface sub-boards mounted on the main board, because products from a few manufacturers require that the V_{pp} values at both ends of the connection be identical; otherwise, although link establishment can be completed, communication will be disabled. If connecting to a Four Star Electronics product, this step is not necessary; Four Star Electronics' $V_{pp}=1.0V$ and $V_{pp}=2.4V$ signals are compatible, as are those of most other manufacturers.

Single-Pair Ethernet and Ethernet-APL Universal Switches

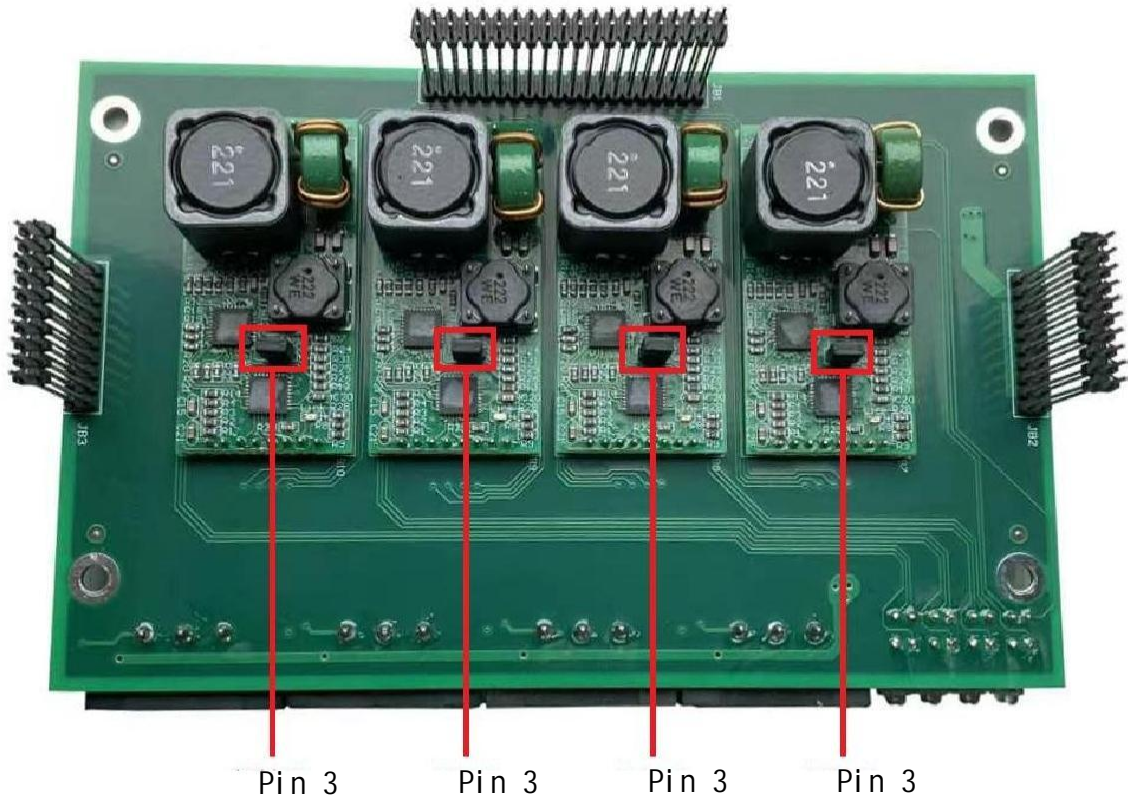

J3 is one of ten communication pins on three circuit boards.
Short circuit: $V_{pp} = 1.0V$
Open circuit: $V_{pp} = 2.4V$



J3 pins on 10 communication sub-boards across three circuit boards

Installation and Usage Guide

When not using PoDL power, there are no specific requirements for the cross-sectional area of the SPE (APL) twisted-pair cable; typically, AWG 22 (cross-sectional of approximately 0.3 mm^2) is sufficient, with a maximum transmission distance of 1,000 meters.

When PoDL power supply is enabled, since power current flows through the SPE (APL) cable, a certain voltage drop occurs across the cable. The higher the power, the greater the voltage drop; the higher the cable resistance, the greater the voltage drop. Therefore, for different power levels of Powered Devices (PDs), the cable cross-sectional area determines the maximum transmission distance. Refer to the IEEE 802.3cg standard in the table below.

IEEE 802.3cg Class Power Requirements Matrix for PSE and PDs

Class Symbol and Unit	Class Description	Class 10	Class 11	Class 12	Class 13	Class 14	Class 15
$V_{PSE} (V)$	PSE output voltage	20 to 30			50 to 58		
$I_{PI(MAX)} (mA)$	Cable current	92	240	632	231	600	1579
$P_{CLASS(MIN)} (W)$	PSE output power	1.85	4.8	12.63	11.54	30	79
$V_{PD(MIN)} (V)$	PD input voltage	14			35		
$P_{PD(MAX)} (W)$	PD power	1.23	3.2	8.4	7.7	20	52
$R_{LINK_SEG_LOOP} (\Omega)$	Cable resistance	65	25	9.5	65	25	9.5

IEEE 802.3cg Class Power Requirements Matrix Example Link Segment Maximum Distances

Example Cable	Maximum Lengths (m)					
	Class 10	Class 11	Class 12	Class 13	Class 14	Class 15
14AWG, 14 Gauge Cable	1000 ¹	1000	400	1000 ¹	1000	400
18AWG, 18 Gauge Cable	1000	400	158	1000	400	158
24AWG, 24 Gauge Cable	300	100	40	300	100	40

1. FO2G-IE3G-10TIL10 as a Single-Pair Ethernet Switch:

The FO2G-IE3G-10TIL10 switch is a physical-layer switch that enables bidirectional transparent data conversion between single-pair Ethernet networks and between single-pair Ethernet and standard Ethernet. It supports all industrial Ethernet upper-layer protocols, such as PROFINET, MODBUS TCP/IP, Ethernet/IP, EtherCAT, CC-Link IE, and POWERLINK. When configuring the network software topology for these upper-layer protocols

, it does not need to be treated as a communication device during configuration; it can simply be regarded as a single cable. Switches operating in transparent mode also do not require an IP address.

Single-Pair Ethernet and Ethernet-APL Universal Switches

When used as a single-pair Ethernet switch, in accordance with the IEEE 802.3cg standard, Power over Data Line (PoDL) provides the following two voltage levels. Ensure that the operating power supply voltage of this product matches the voltage of the user's SPE Powered Device (PD):

24 VDC (range 20 V–30 VDC) supports PoDL power classes 10, 11, and 12, with a PoDL output power of ≥ 12.63 W.

54 VDC (range: 50 V–58 VDC), supporting PoDL power classes 13, 14, and 15, with a PoDL output power of ≥ 79 W per SPE port.

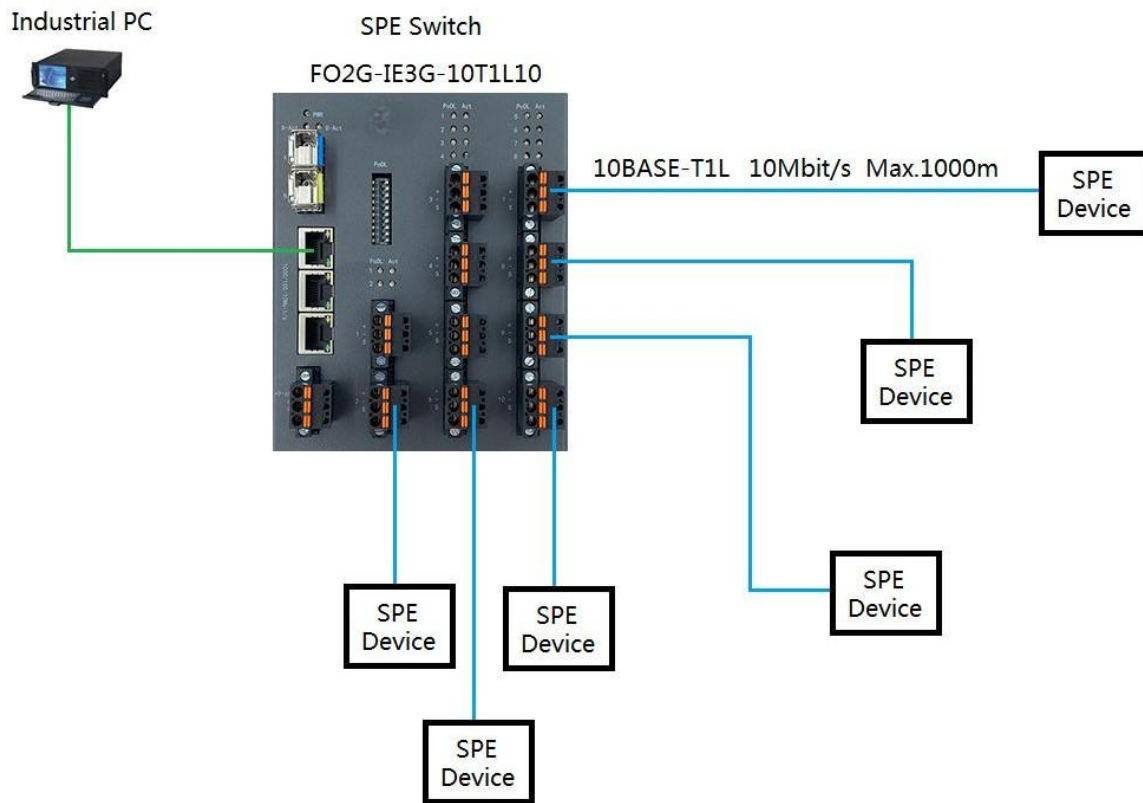

FO2G-IE3G-10T1L10 Switch Connection Topology

Single-Pair Ethernet and Ethernet-APL Universal Switches

The FO2G-IE3G-10T1L10 single-pair Ethernet switch can be used standalone or connected to multiple other switches via standard Ethernet ports or fiber optic interfaces. Both its standard Ethernet ports and fiber optic interfaces support ring networks, allowing for the formation of fiber-optic ring networks, Ethernet cable ring networks, and hybrid fiber-Ethernet cable ring network structures. There is no limit to the number of switches that can be connected. The figure below shows a hybrid fiber-Ethernet cable ring network topology.

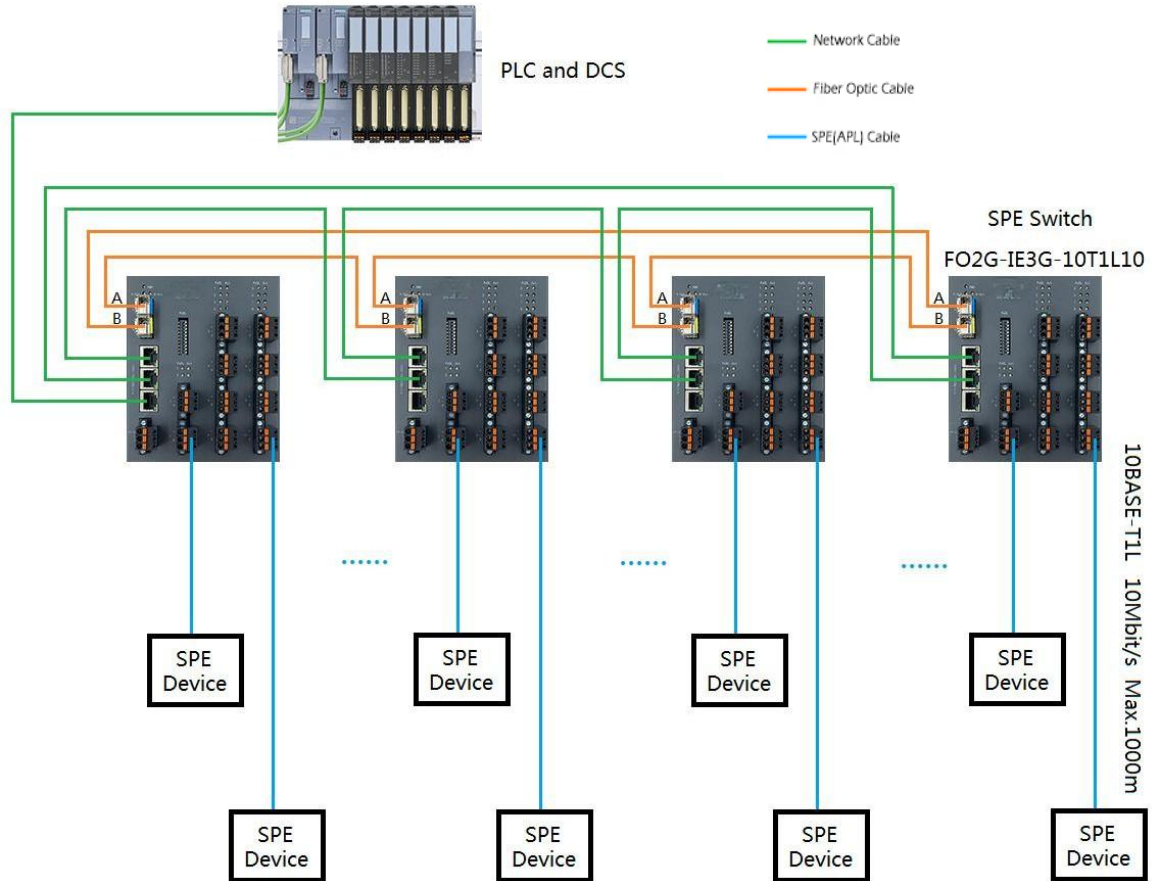

FO2G-IE3G-10T1L10 Switch Configuration for a Hybrid Fiber-Ethernet Ring Topology

Single-Pair Ethernet and Ethernet-APL Universal Switches

2. FO2G-IE3G-10T1L10 as an Ethernet-APL Field Switch:

When used as an Ethernet-APL field switch, this product is an Ethernet-APL field switch with auxiliary power supply. Its 10 single-pair Ethernet interfaces serve as APL spur interfaces, providing point-to-point connections to various APL devices in the field (such as meters, sensors, and actuators). In this configuration, the product operates on a 12 VDC power supply (range: 9 V to 15 VDC) and supports PoDL power levels A and C, with each APL spur interface providing a PoDL output power of ≥ 1.1 W. The uplink standard Ethernet and fiber optic interfaces connect to various controllers, and both Ethernet and fiber ports support ring network connections.

When the FO2G-IE3G-10T1L10 functions as an Ethernet-APL field switch, the signal peak-to-peak voltage (V_{pp}) is 1.0 V, and the port type is SPCX (S: APL Spur; P: Power Supply Port; 4: 15 V DC/1.11 W; X: Non-hazardous area/Non-intrinsically safe in hazardous areas).

When the FO2G-IE3G-10T1L10 functions as an Ethernet-APL field switch, both its standard Ethernet ports and fiber-optic ports support ring topologies. It can form fiber-optic ring networks, Ethernet cable ring networks, and hybrid fiber-Ethernet cable ring network structures. There is no limit to the number of switches that can be connected. The figure below shows a hybrid fiber-Ethernet cable ring network topology.

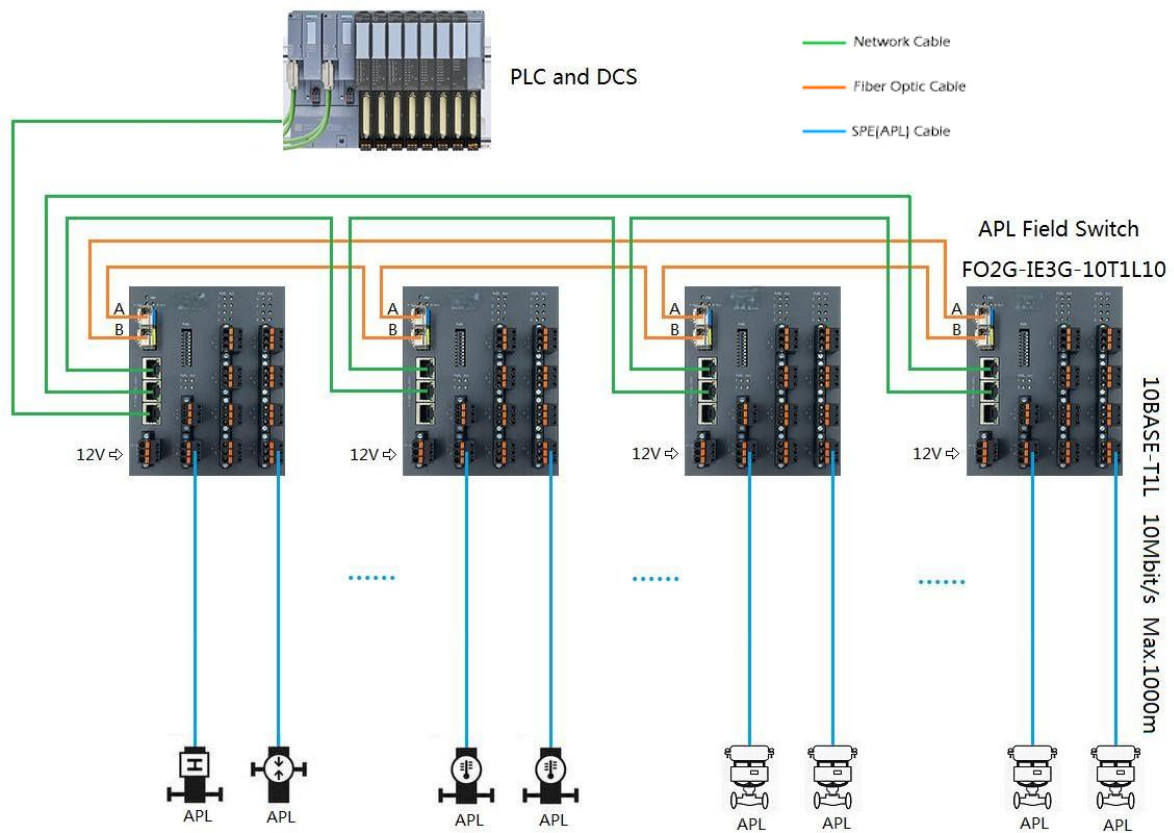

Fiber-Ethernet Hybrid Ring Topology for the FO2G-IE3G-10T1L10 Used as an APL Field Switch

3. FO2G-IE3G-10T1L10 as an Ethernet-APL Power Switch:

When this product functions as an Ethernet-APL power switch, its 10 single-pair Ethernet ports serve as APL trunk interfaces, connecting to various APL field switches equipped with trunk interfaces. Field switches are field switches without auxiliary power supplies; they are powered by the data lines from the FO2G-IE3G-10T1L10's single-pair Ethernet ports (which function as APL trunk interfaces in this configuration). In this configuration, the product operates at a supply voltage of 48 VDC (range: 45 V–50 VDC), supports PoDL power levels 3 and 4, and provides a maximum PoDL output power of 92 W per APL trunk interface. The uplink standard Ethernet ports and fiber optic interfaces connect to various controllers; both Ethernet and fiber ports support ring network configurations.

When the FO2G-IE3G-10T1L10 functions as an Ethernet-APL power switch, the peak-to-peak signal voltage (V_{pp}) is 2.4 V, and the peak current is 4 X (T: APL trunk; P: power supply port; 4: 50 V DC/92 W; X: non-hazardous area/hazardous area—non-intrinsically safe).

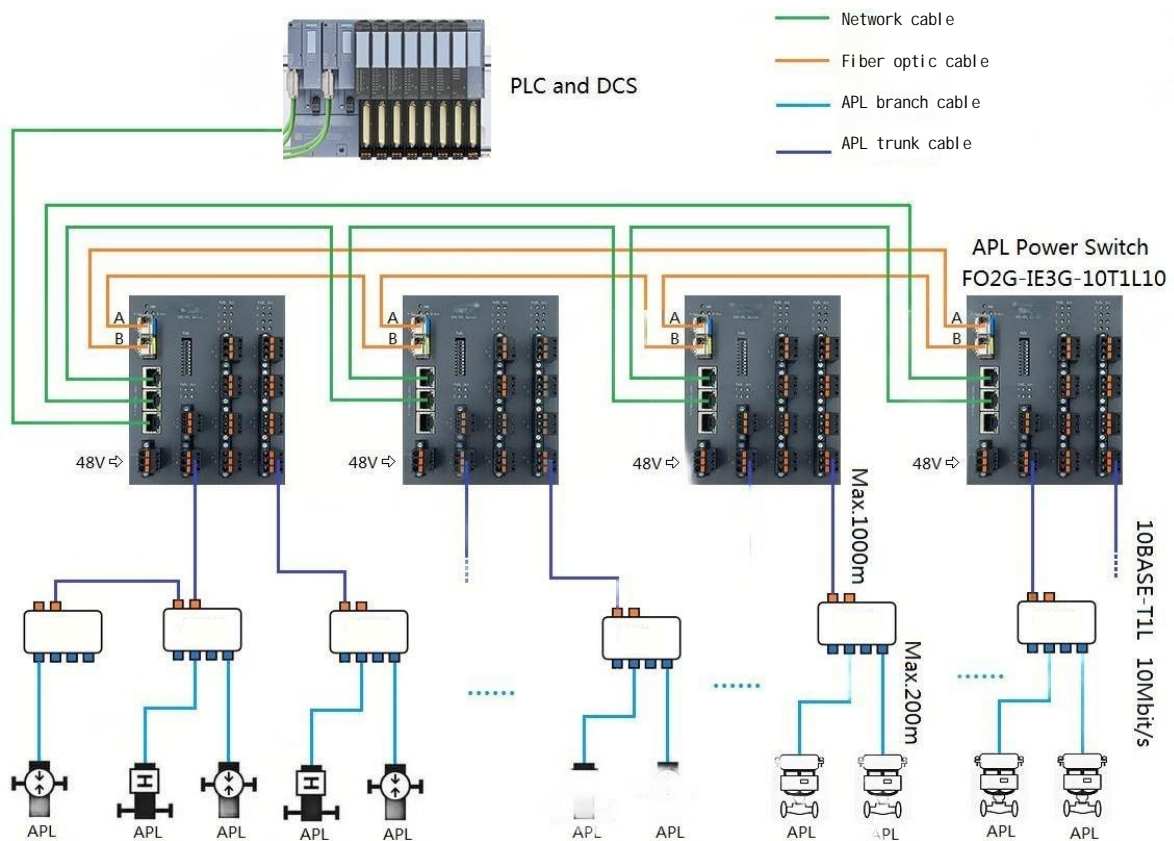

FO2G-IE3G-10T1L10 used in a hybrid fiber-and-Ethernet loop topology for APL power switches

4. Cascading Expansion of the FO2G-IE3G-10T1L10 via SPE (APL) Ports:

Cascade expansion between FO2G-IE3G-10T1L10 units is typically achieved via Ethernet or fiber ports. However, in situations where fiber deployment is impractical and distances are significant—such as long drag cables in mine control systems or elevators in high-rise buildings—in such cases, SPE (APL) ports can be used to connect the devices and achieve cascading expansion. The maximum cable length between any two adjacent SPE (APL) ports can reach 1000 meters. SPE (APL) Port 1 and SPE (APL) Port 2 on this product support a ring topology, while the other SPE (APL) ports do not support a ring topology.

Be sure to disable PoDL power supply on the SPE (APL) ports used to connect switches to each other to prevent a PoDL power short circuit caused by accidentally reversing the positive and negative terminals of the SPE cable.

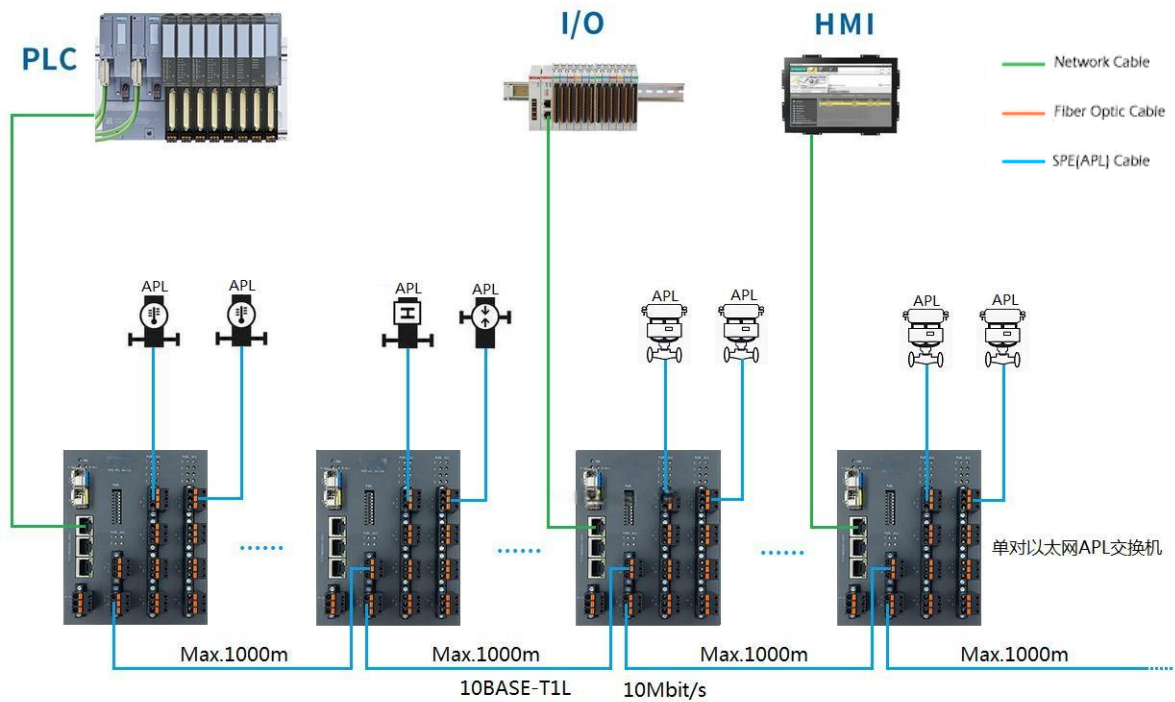

Make sure to turn off the PoDL power supply to SPE1 and SPE2.

Expanding the FO2G-IE3G-10T1L10 Switch via SPE (APL) Port Cascading

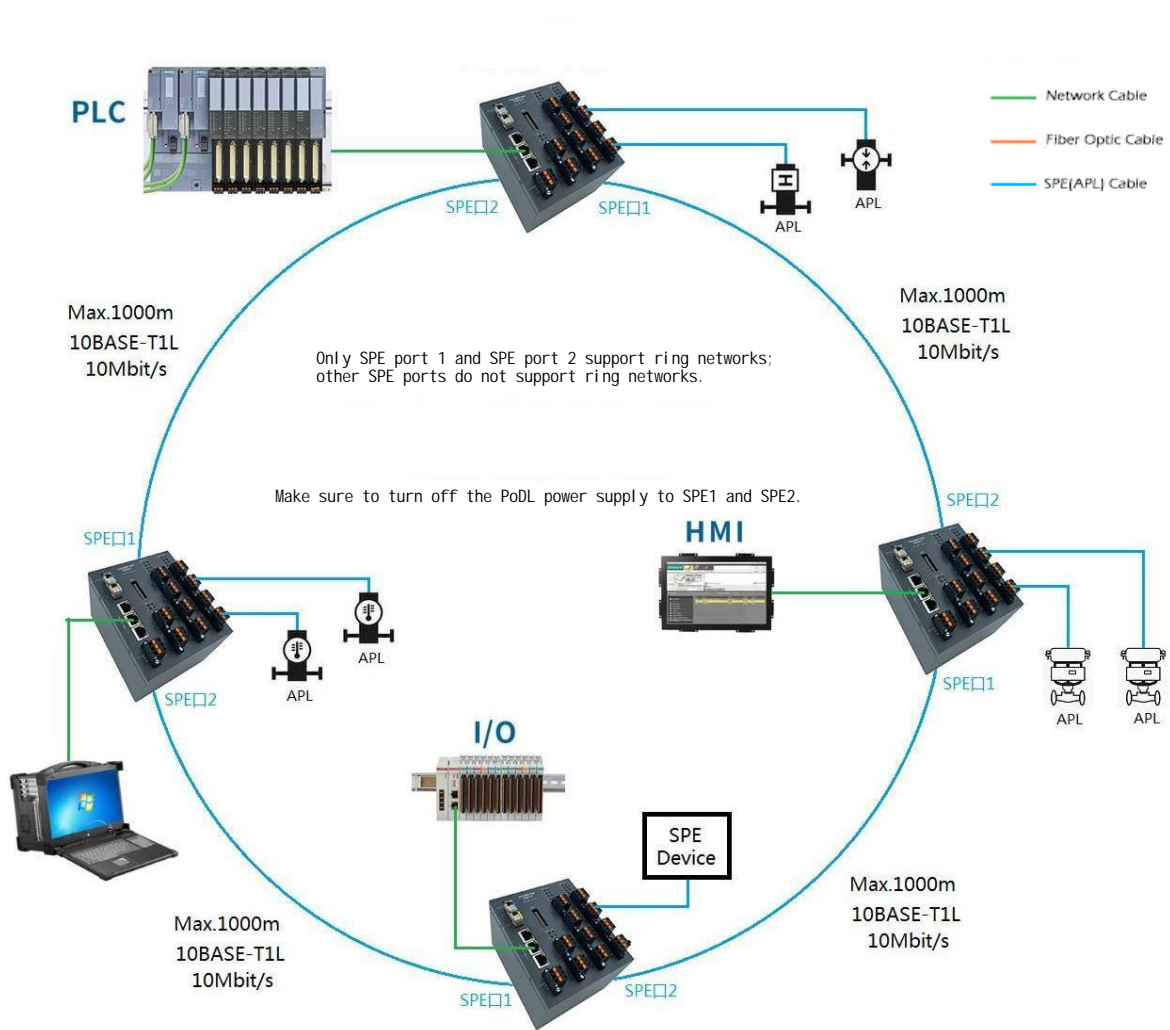

FO2G-IE3G-10T1L10 Switch Configured in a Ring Topology via SPE (APL) Ports

Disclaimer: This document provides guidance for users of the FO2G-IE3G-10T1L10 single-pair Ethernet and Ethernet-APL universal switch. Due to the rapid development of new technologies, actual product features are subject to change.